

Technical Description

Level Switch Type T-20_F...

Measuring transducer

Type KR-163... ; KR-163/A/Ex...; ET-52.; ET-580; ET-R...; XR-...; KR-168...; KR-268...;
OAA-100...; OAA-200-...; OAA-300...; OAA-500...

1. Design of the overfull cut-out device

The overfull cut-out device consists of the level switch (1), which works according to the float principle, and a separate measuring transducer (2) (KR-163..., KR-163Aex, KR-268..., XR-...; OAA-100...) or a level switch (1) with integrated measuring transducer (2) (ET-520...; ET-521; ET-522; ET-580) or a level switch FR (1,2) (float – magnetic switch) which provide a binary switch signal at the output.

This binary signal can be delivered directly or indirectly via a signal amplifier (4), to the alarm device (5a) or the control device (5b) with its control element (5c).

In the case of overfull cut-out devices which consist of the level switch (1) with downstream alarm signal (OAA-200...; OAA-300... resp. OAA-500...) the measuring transducer (2) and alarm device (5a) are also integrated.

The untested system parts of the overfull cut-out device, such as signal amplifier (4), the alarm device (5a) or the control device (5b) with the control element (5c) must conform with the requirements of Sections 3 and 4 of the approval principles (German ZG-ÜS) for overfull cut-out devices.

1.1 Schematic design of the overfull cut-out device

1.1.1 Level switch (1), separate measuring transducer (2)

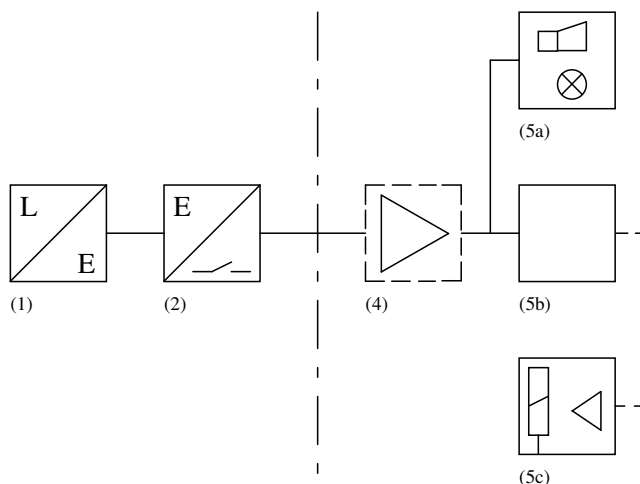

- (1) Level switch (immersible magnetic probe)
- (2) Measuring transducer
- (4) Signal amplifier
- (5a) Alarm device (with horn and signal lamp)
- (5b) Control device
- (5c) Control element

1.1.2 Level switch (1) with integrated measuring transducer (2)

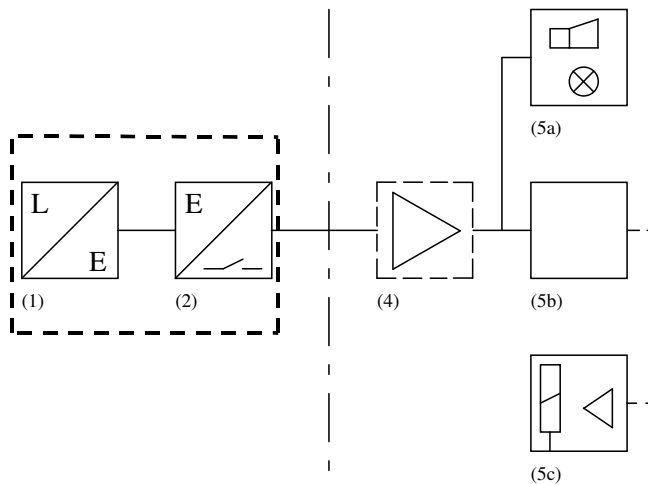

- (1) Level switch (immersible magnetic probe)
- (2) Measuring transducer integrated
- (4) Signal amplifier
- (5a) Alarm device (with horn and signal lamp)
- (5b) Control device
- (5c) Control element

1.1.3 Level switch (1) with integrated measuring transducer (2) und integrated alarm device (5a)

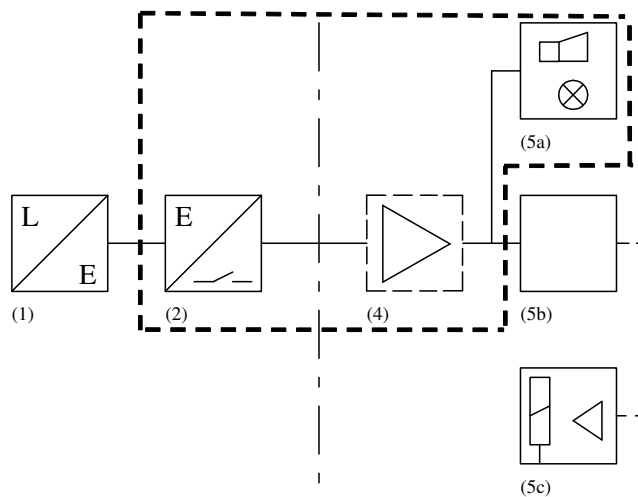

- (1) Level switch (immersible magnetic probe)
- (2) Measuring transducer integrated
- (4) Signal amplifier integrated
- (5a) Alarm device integrated (with horn and signal lamp)
- (5b) Control device
- (5c) Control element

1.2 Function description

The float of the level switch rests below the set switch point on a stop ring and actuates the reed contacts located in the guide tube with the permanent magnets installed in the float. When the float is raised by the rising liquid level, the reed contact (s) opens (t) and triggers the alarm.

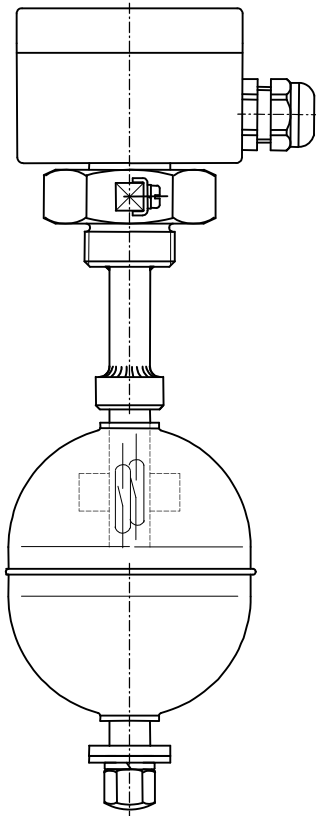

Fig.: Level switch

In addition to the float for the overfull cut-out device (**F-contact**) further floats below the response level can record the level for general ICA purposes either punctual or continuously. Reed contacts can be used as individual make contacts, break contacts or changeover contacts for this purpose. If the level is to be recorded continuously, several reed contacts are used so that they function as "tap" of a resistor chain.

The **F-contact** consists of two reed contacts arranged in parallel, which are series connected.

Line monitoring between the **F-contact** and the associated measuring transducer is conducted by the valuation of the electric circuit resistance. In the operational state of the level switch, the circuit resistance is approx. 1 k Ω , in the case of overfull alarm approx. 12 k Ω . Circuit resistances of \ll 1 k Ω or \gg 12 k Ω are rated as line error.

The **FR-contact** consists of a reed contact with a series-connected contact protection resistor.

The overfull cut-out device works according to the quiescent current principle, i.e. in the event of a fault, the contact for the connection of the signaling and control devices is opened.

For the use in explosion-prone areas only devices intended for this purpose may be used. The pertinent safety regulations regarding the erection and operation of electrical systems in Ex-area must be complied with.

ELB Füllstandsgeräte

Overfull cut-out device with level switch for stationary containers to store liquids hazardous to water

z-65.11-404_englischeBeschr_Juli2019.doc

Status: 03.07.2019

Page: 4/30

Signalling Table OAA-100 ...

LED	OAA 100-A1			OAA 100-A3	
	green	red I	red II	green	red
Mains OFF	●	●	●	●	●
Operation	☀	●	●	☀	●
Line error	☀ ●	☀	●	☀ ●	☀
Line error acknowledged	☀ ●	☀ ●	●	☀ ●	☀ ●
Filling alarm	☀	☀	●	☀	☀
Filling alarm acknowledged	☀	☀ ●	●	☀	☀ ●
Line error	☀ ●	●	☀		
Line error acknowledged	☀ ●	●	☀ ●		
Filling alarm	☀	●	☀		
Filling alarm acknowledged	☀	●	☀ ●		

LED off: ●, LED on: ☀, LED flashes: ☀ ●.

Signalling Table OAA-200 ...

LED	Channel LED, 3 coloured		Summary alarm	Horn
Mains OFF, resp. no sensor connected		●	●	Off
Operation, sensor connected	green	☀	●	Off
Line error	red	☀	☀ ●	On
Line error acknowledged	red	☀ ●	☀ ●	Off
Filling alarm, Leak alarm	yellow	☀	☀ ●	On
Filling alarm, Leak alarm acknowledged	yellow	☀ ●	☀ ●	Off
Error rectified	green	☀ ●	☀ ●	Off
Rectified error acknowledged	green	☀	●	Off

LED off: ●, LED on: ☀, LED flashes: ☀ ●.

Signalling Table OAA-300 ...

LED	Channel LED, 3 coloured		Summary alarm	Horn
Mains OFF, resp. no sensor connected		●	●	Off
Operation, sensor connected	green	☀	●	Off
Line error	red	☀	☀ ●	On
Line error acknowledged	red	☀ ●	☀ ●	Off
Error rectified	green	☀ ●	☀ ●	Off
Rectified error acknowledged	green	☀	●	Off
Filling alarm, Leak alarm	yellow	☀	☀ ●	On
Filling alarm, Leak alarm acknowledged	yellow	☀ ●	☀ ●	Off
Error rectified	green	☀ ●	☀ ●	Off
Rectified error acknowledged	green	☀	●	Off

LED off: ●, LED on: ☀, LED flashes: ☀ ●.

ELB Füllstandsgeräte

Overfull cut-out device with level switch for stationary containers to store liquids hazardous to water

z-65.11-404_englischeBeschr_Juli2019.doc

Status: 03.07.2019

Page: 5/30

Signalling Table OAA-500 ...

LED	Channel LED, 3 coloured	Summary alarm	Horn
Mains OFF, resp. no sensor connected	●	●	Off
Operation, sensor connected	green ☀	●	Off
Line error	red ☀	☀ ●	On
Line error acknowledged	red ☀ ●	☀ ●	Off
Filling alarm, Leak alarm	yellow ☀	☀ ●	On
Filling alarm, Leak alarm acknowledged	yellow ☀ ●	☀ ●	Off
Error rectified	green ☀ ●	☀ ●	Off
Rectified error acknowledged	green ☀	●	Off

LED off: ●, LED on: ☀, LED flashes: ☀ ●.

Signalling Table

LED	KR-163 / ET-580		KR-168 / -268 / XR-...			ET- 520../-521	
	green	red	green	yellow	red	green	red
Mains OFF	●	●	●	●	●	●	●
Operation	☀	●	☀	●	●	☀	●
Line error	●	☀	☀	☀	☀	●	☀
Filling alarm	☀	☀	☀	☀	●	☀	☀

LED off: ●, LED on: ☀

1.3 Type key

1.3.1 Measuring transducer (2)

1.3.1.1 Measuring transducer KR-163...

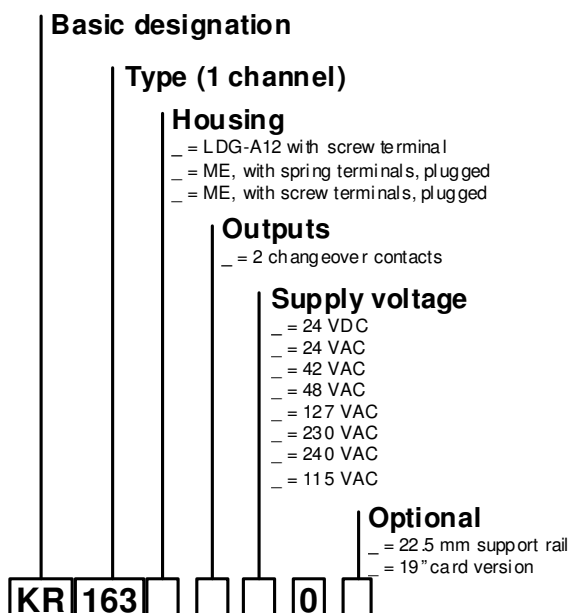

1.3.1.2 Measuring transducer KR-168... resp. KR-268...

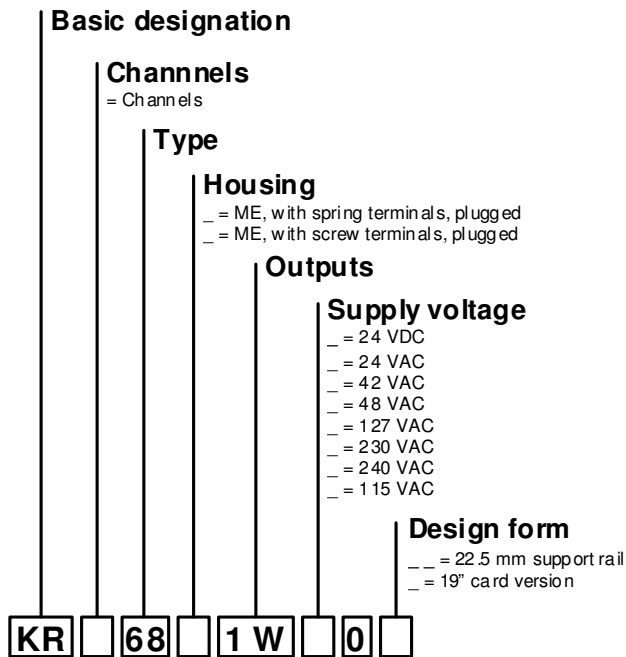

1.3.1.3 Measuring transducer EX-range: KR-163AEx...

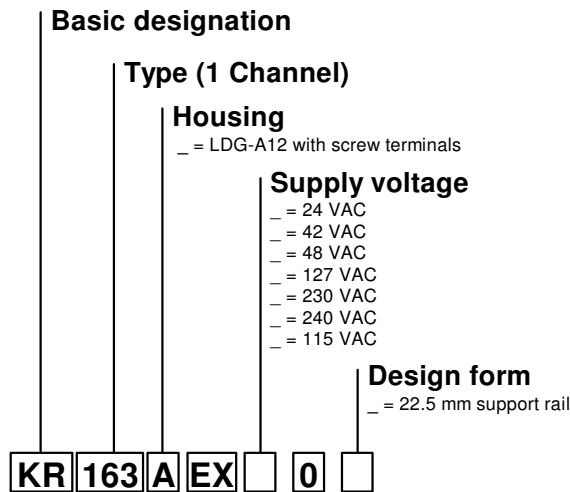

1.3.1.4 Measuring transducer OAA-100-A1...

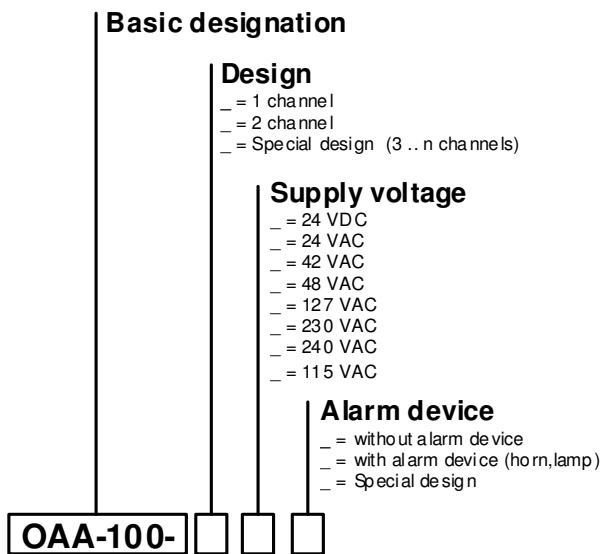

1.3.1.5 Measuring transducer OAA-100-A3...

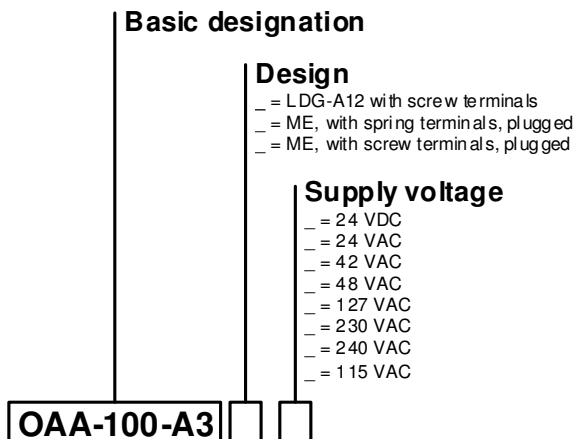

1.3.1.6 Measuring transducer OAA-300-...

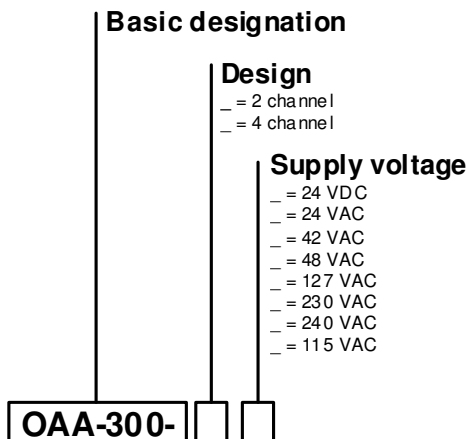

1.3.1.7 Measuring transducer OAA-500-...

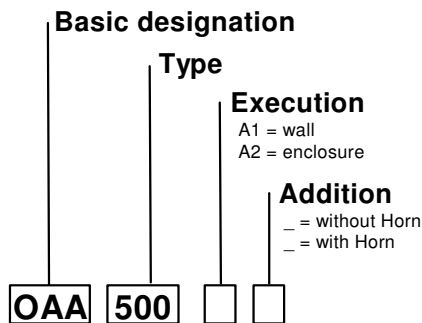

1.3.1.8 Measuring transducer OAA-200-...

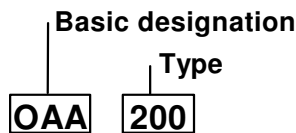

1.3.1.9 Measuring transducer Series XR-...

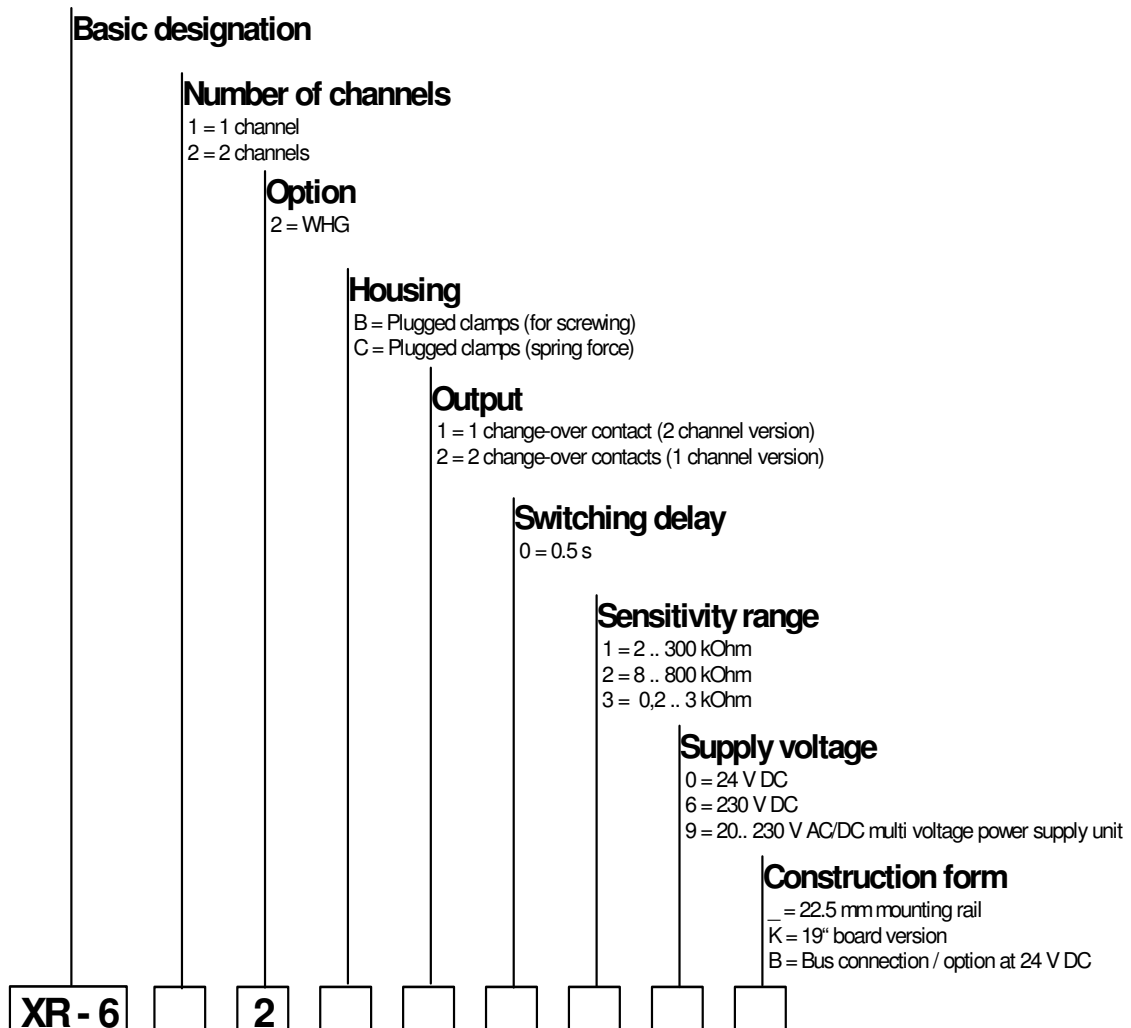

1.3.2 Level switch (1)

1.3.2.1 Level switch T 20x F

Basic designation

Guide tube

- _ = Ø 10 mm for PP 40
- _ = Ø 16 mm for PE 52, PP 52, PVC 52
- _ = Ø 20 mm for PE 78, PP 78, PVC 78

Safety function

- F = Overfull cut-out
- FR = Overfull cut-out (no Ex-version)

Material screw connector + Guide tube

- _ = PE
- _ = PP (Note: Ø 10 only in PP)
- _ = PVC
- _ = PVDF
- _ = PE-EL (electrically conducting)
- _ = PP-EL (electrically conducting)
- _ = PVC-EL (electrically conducting)

Connection thread

- _ = G 1"
- _ = G1.1/4"
- _ = G1.1/2"
- _ = G2"
- _ = G3"
- _ = Cap nut G2.3/4"
- _ = Cap nut S 100 x 8
- _ = Flange

Design

- _ = adjustable
- _ = firm welded

Additional switch contacts

- _ = without (only F-contact)
- _ = 1 ... 5 contacts / without F-contact
- _ = continuous measuring chain

Floater material

- _ = PE
- _ = PP
- _ = PVC
- _ = PVDF

Connection

- _ = Polyester connector housing
- _ = Aluminium connector housing
- _ = PE connector housing / Alternative PE-EL (electr. conducting)
- _ = PP connector housing / Alternative PP-EL (electr. conducting)
- _ = PVC connector housing / Alternative PVC-EL (electr. conducting)
- _ = Plug connection
- _ = Unconnected cable end

Length

- _ = LF-dimensions in mm

Option

- _ = Ex

T20

1.3.2.2 Level switch T 20x F - 24V

Basic designation

Guide tube

- _ = Ø 10 mm for PP-40
- _ = Ø 16 mm for PE 52, PP 52, PVC 52
- _ = Ø 20 mm for PE 78, PP 78, PVC 78

Safety function

F = Overfull cut-out

Material screw connector + Guide tube

- _ = PE
- _ = PP (Note: Ø 10 only in PP)
- _ = PVC
- _ = PVDF
- _ = PE-(electrically conducting)
- _ = PP-EL (electrically conducting)
- _ = PVC-EL (electrically conducting)

Connection thread

- _ = G 1"
- _ = G1.1/4"
- _ = G1.1/2"
- _ = G2"
- _ = G3"
- _ = Cap nut G2.3/4"
- _ = Cap nut S 100 x 8
- _ = Flange

Design

- _ = adjustable
- _ = firm welded

Float material

- _ = PE
- _ = PP
- _ = PVC
- _ = PVDF

Connection

- _ = Polycarbonate connector housing
- _ = PE connector housing / Alternative PE-EL (electr. conducting)
- _ = PP connector housing / Alternative PP-EL (electr. conducting)
- _ = PVC connector housing / Alternative PVC-EL (electr. conducting)
- _ = plug connection

Length

- _ = LF-dimensions in mm

Optional

- _ = ET-52x (KR-24V)
- _ = ET-...

T20

1.3.2.3 Level switch T 20x F Ex

Basic designation

Guide tube

- 3 = 15 mm for float VA76 u. VA90
- 4 = 12 mm for float VA44 bis VA60
- 9/0 = 18 mm for float VA10
- 4/0 = 12 mm float VA60 (Kabelschw.)
- 5/0 = 8 mm for float VA27.. 40 + PP19 (unconn. cable end)
- 7/0 = 8 mm for float VA27.. 40 + PP19 ((unconn. cable end.))

Safety function

F = Overfull cut-out

Connection thread

- _ = cyl. pipe thread 1/8" ... 3.1/2"
- _ = conical pipe thread 1/8" ... 3.1/2"
- _ = Flange
- _ = Special designs according to customer requirement

Design

- _ = adjustable
- _ = firm welded

Additional switch contacts

- _ = Number of contacts (1 ... 5 contacts / without F-contact)
- _ = continuous measuring chain

Number of floaters

- _ = Number! (1 .. n)

Floater design

- _ = Ball, stainless steel, VA 27
- _ = Ball, stainless steel, VA 40
- _ = Ball, stainless steel, VA 50
- _ = Ball, stainless steel, VA 60
- _ = Ball, stainless steel, VA 10
- _ = Oval, stainless steel, VA 76
- _ = Oval, stainless steel I, VA 90
- _ = Cylinder, stainless steel VA 30
- _ = Cylinder, stainless steel, VA 44 bzw. VA 44L
- _ = Cylinder, Polypropylene, PP 19 (only for IIA resp. IIB)

Connection

- _ = Polyester connection housing
- _ = Aluminium connection housing
- _ = Unconnected cable end (with spec: reed contacts or PCB)

Explosion protection

- _ = ATEX II 1 G Ex ia IIC / IIB T 6 resp.
II 1/2 G Ex ia IIC / IIB T 6

Length

- _ = LF-dimensions in mm

T20

1.4 Dimensional drawings

1.4.1 Dimensional drawings level switch (1)

1.4.1.1 Dimensional drawings for level switch – Metal version

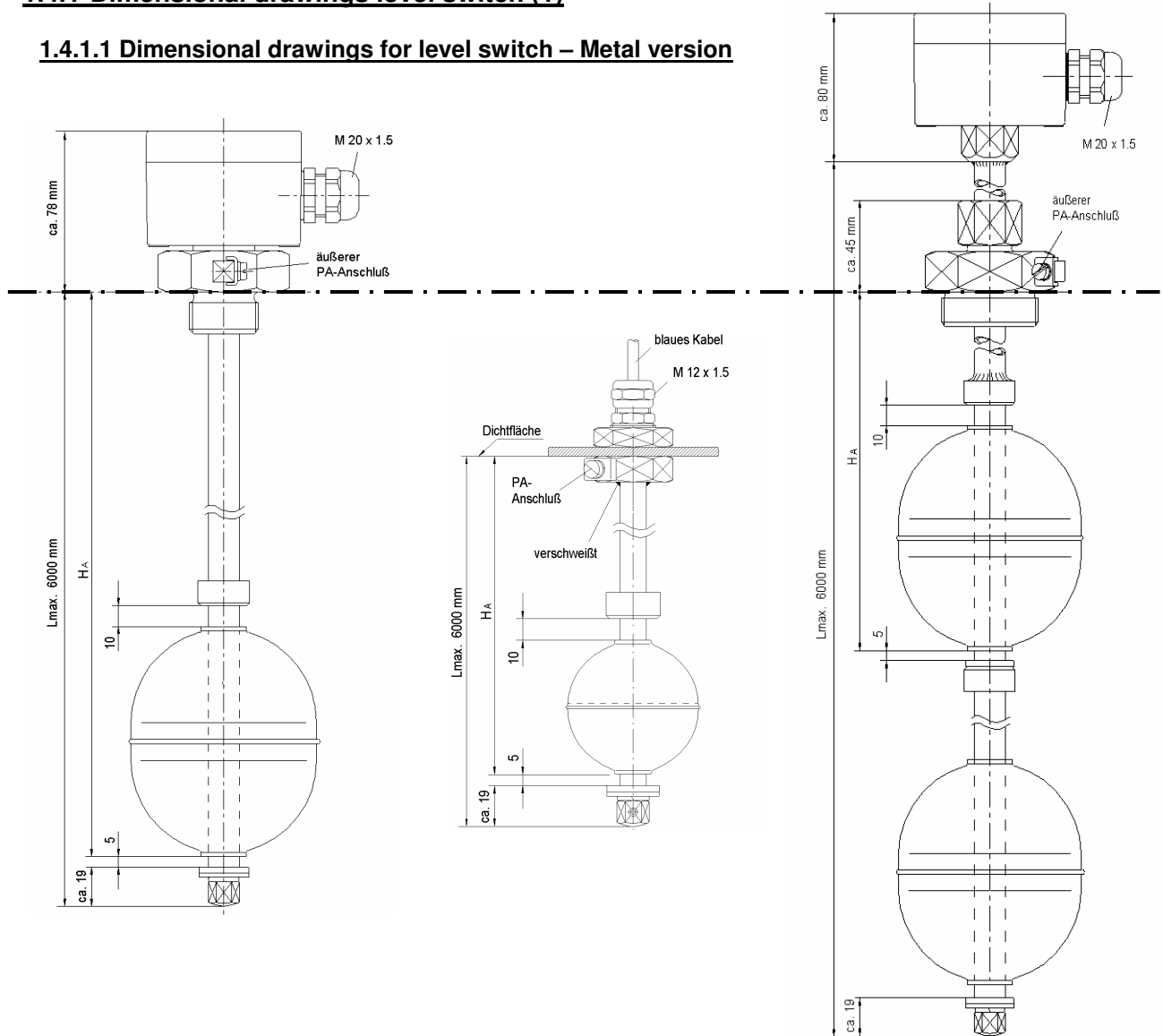

Fixed version:
T-201 / T-202 / T-203 / T-204 /
T-209 / T-209/0

Unconnected cable end version:
T-204/0 resp. T-205/0 / T-207/0

Adjustable version:
T-201 / T-202 / T-203 / T-204

1.4.1.2 Dimensional drawings for level switch – Plastic version

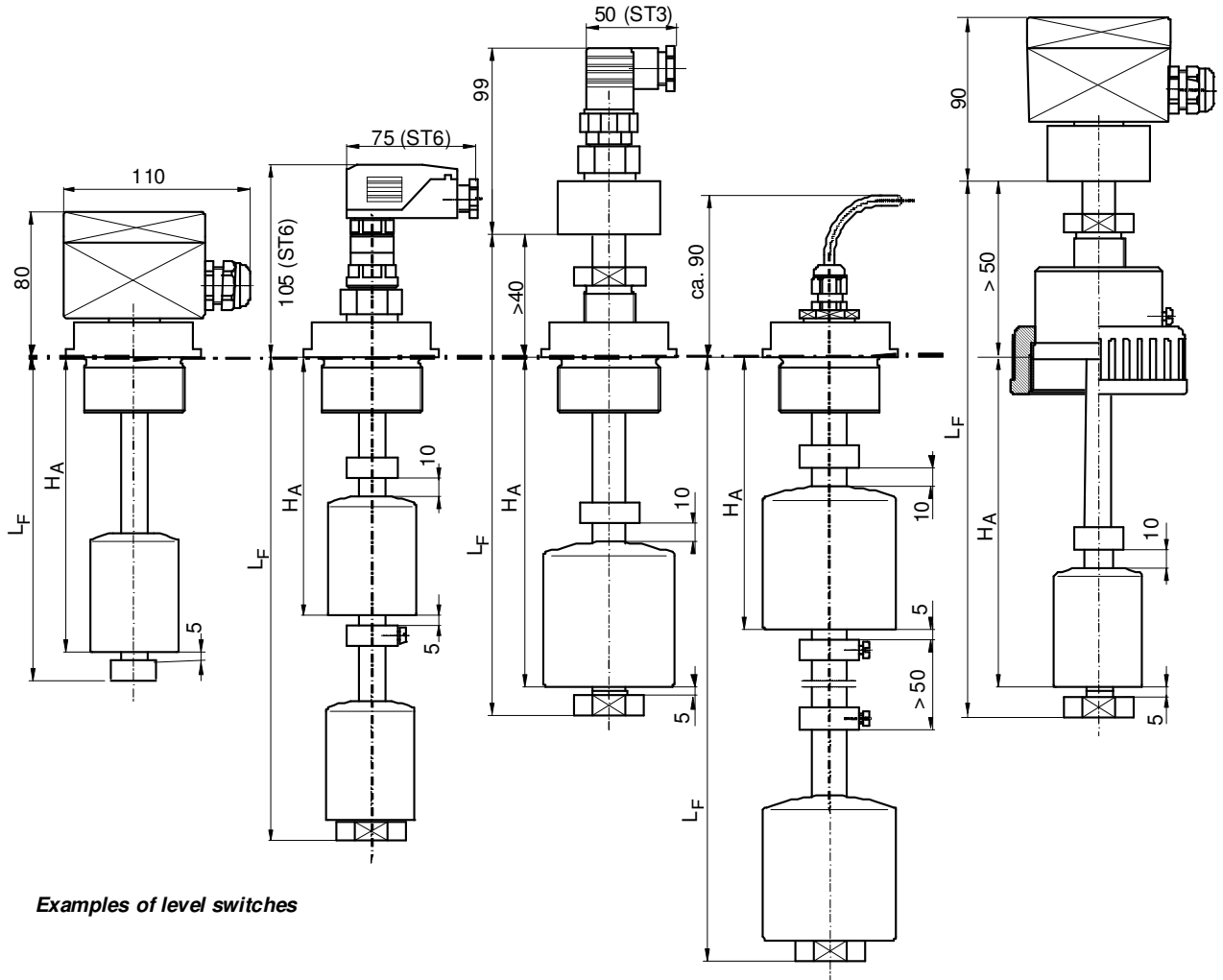

Examples of level switches

T200.F..
with jack
and
lower stop

T200.F..
Plug connection
Two floaters
with another contact

T208.F..
Plug connection
Adjustable
version

T208.F..
Cable connection with
two floaters
and continuous
Section of
measurement

T200.F..
Adjustable version.
Jack with cap nut
G 2 3/4"

L_F = Guide tube length (max. 6000 mm)

H_A = Response length

1.4.2 Dimensions and immersion depth of the floaters

1.4.2.1 Plastic floater

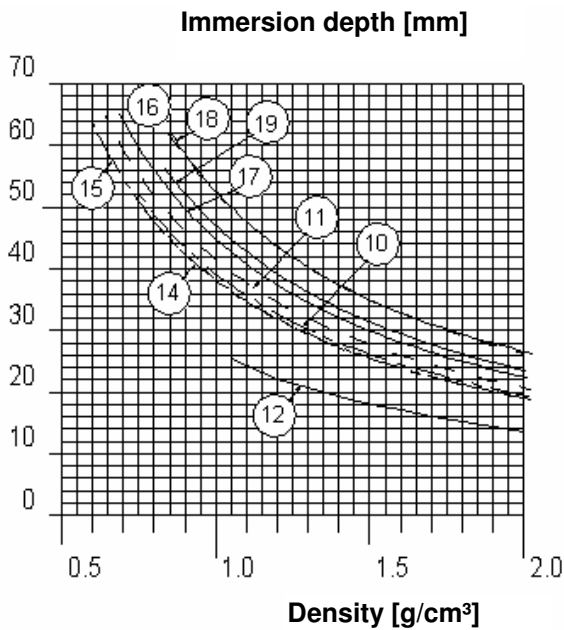

1.4.2.2 Metal floater

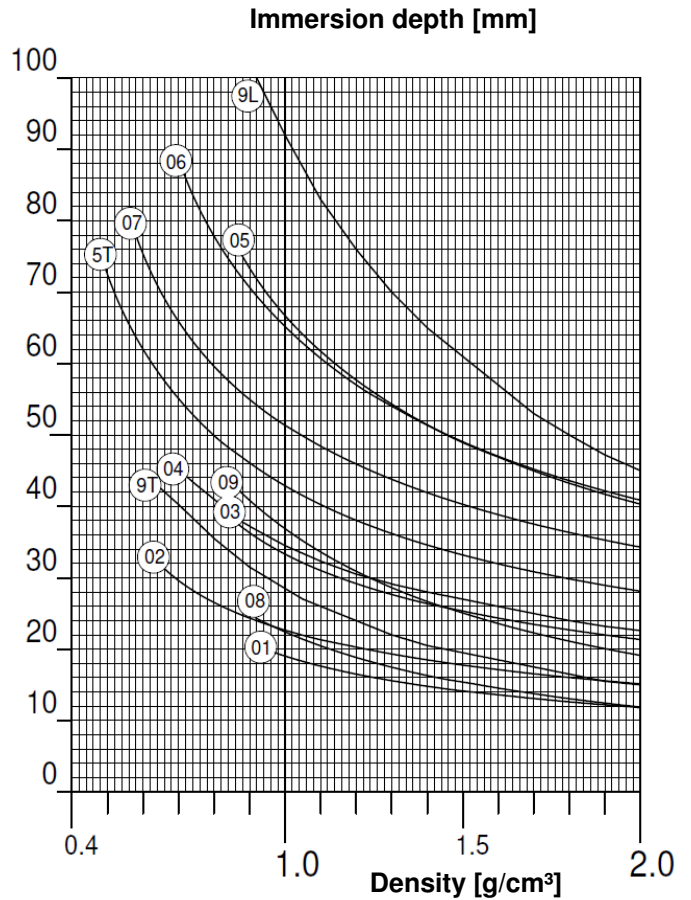

1.4.2.3 Physical data for the floaters

Floater type	Dimensions	Material	max. pressure (bar)	min. density (g/cm ³)	
01	VA27	29 x 28 mm	1.4571	15	0.81
02	VA40	43 x 42 mm	1.4571	16	0.60
03	VA50	52 x 52 mm	1.4571	20	0.75
04	VA60	63 x 62 mm	1.4571	20	0.65
05	VA76	80 x 96 mm	1.4571	20	0.81
5T	TI76	80 x 96 mm	3.7035	15	0.50
06	VA90	94 x 110 mm	1.4571	20	0.67
07	VA10	105 x 102 mm	1.4571	20	0.54
08	VA30	27 x 31 mm	1.4571	10	0.78
09	VA44	44 x 52 mm	1.4571	15	0.76
9T	TI44	44 x 52 mm	3.7025	15	0.65
9L	VA44L	44 x 132 mm	1.4571	10	0.73
10	PE52	Ø 52 x 63 mm	PE	6	0.72
11	PE78	Ø 78 x 80 mm	PE	6	0.60
12	PP19	Ø 19 x 31 mm	PP	unpressurised	1.06
14	PP52	Ø 52 x 65 mm	PP	6	0.72
15	PP78	Ø 78 x 80 mm	PP	6	0.59
16	PT78	Ø 80 x 80 mm	PTFE	6	0.79
17	PV78	Ø 78 x 80 mm	PVC	6	0.63
18	PV55	Ø 55 x 65 mm	PVC	6	0.82
19	PF52	Ø 52 x 65 mm	PVDF	6	0.83
20	PP40	Ø 40 x 38 mm	PP	unpressurised	0.46

1.4.3 Dimensional drawings for measuring transducers (2)

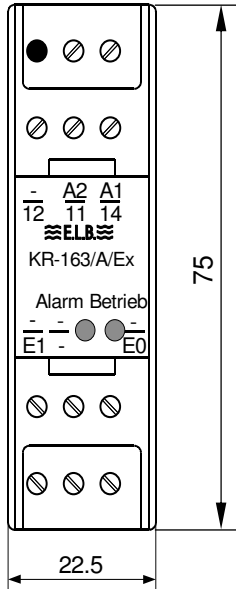

Housing for types:
 KR-163/A/Ex..
 KR-163/A/..
 OAA-100-A3-A..
 XR-

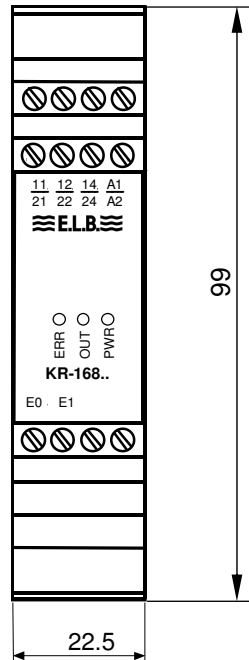

Housing for types:
 KR-168/B/..
 KR-268/B/..
 KR-163/B/..
 OAA-100-A3-B...

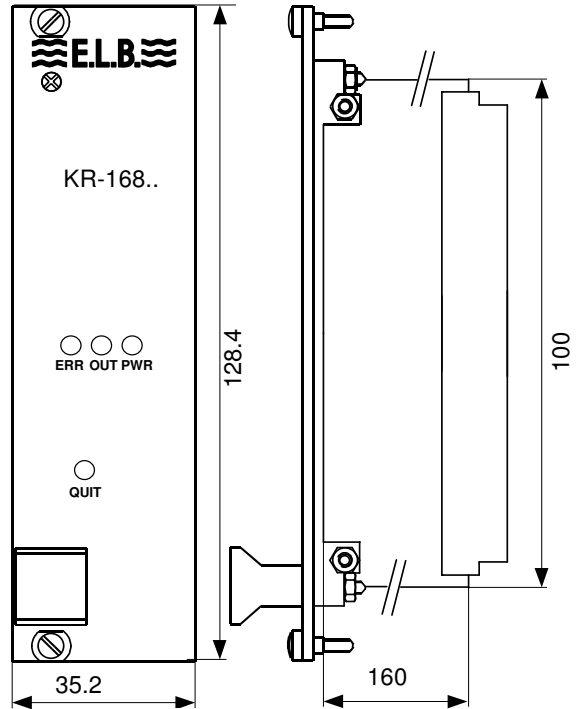

Housing for types:
 KR-168/B/.../K
 KR-268/B/.../K
 OAA-100-K-...

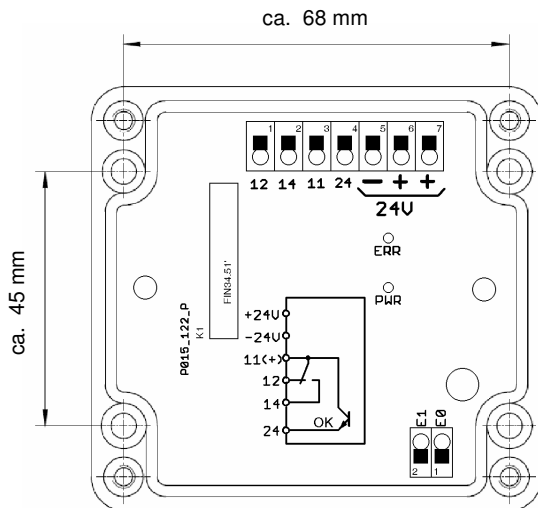

Housing dimensions ET-520a:
 75 mm x 80 mm

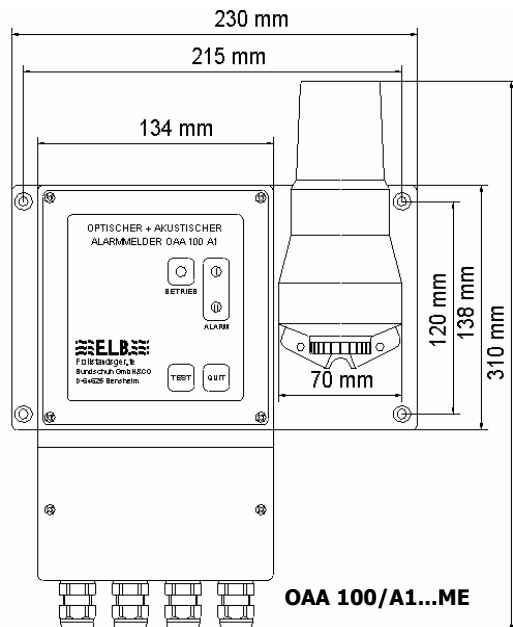

OAA 100/A1...ME

EL.B. Füllstandsgeräte

Overfull cut-out device with level switch for stationary containers to store liquids hazardous to water
 z-65.11-404_englischeBeschr_Juli2019.doc Status: 03.07.2019 Page: 17/30

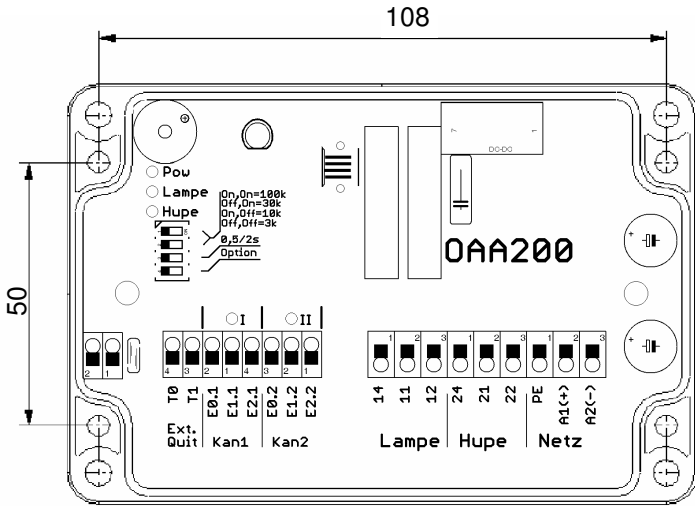

housing dimensions:
120 mm x 80 mm x 57 mm

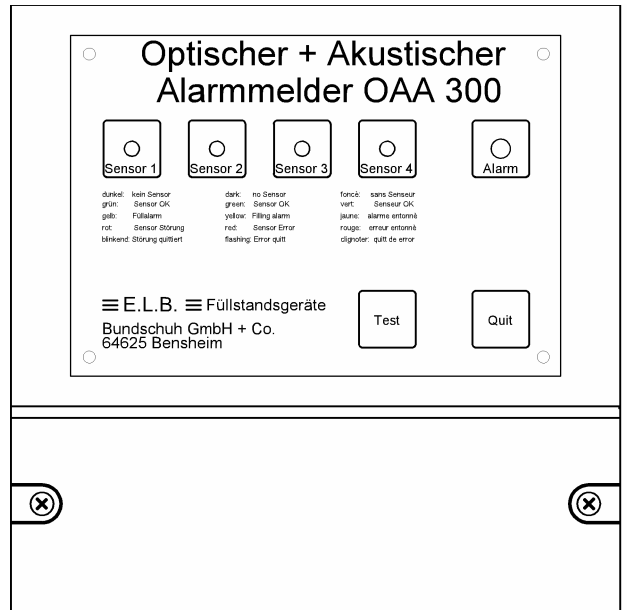

housing dimensions: 170 x 165 x 85 mm

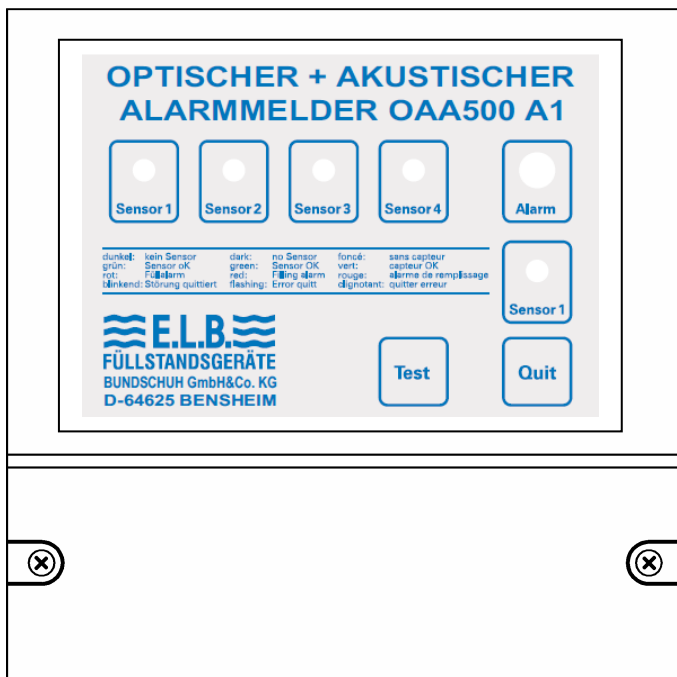

housing dimensions:
137 mm x 186 mm (without cable glands) x 103 mm

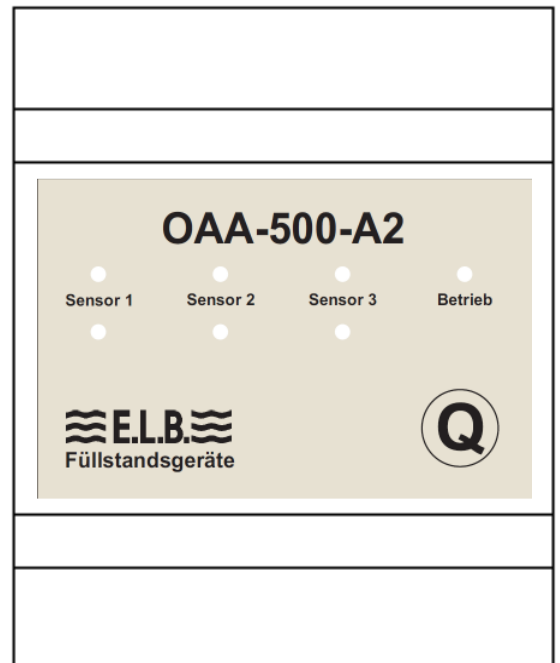

housing dimensions:
86 mm x 70 mm x 60 mm

1.4.4 Technical data for level switch (1)

Connection ^(a)	of suitable material, Cable connection or plug
Protective type accord. to DIN EN 60529	IP 65 (jack) resp. IP 68 (guide pipe)
Mounting type	Screw-in thread: G 1/8" ... G 3 1/2"
Guide tube length	max. 6 m
Operating pressure	see floater
Density of liquid	see floater
Switching hysteresis	typ. 2 mm
Switch point tolerance	max. 5 mm
Resistance value level switch (F-contact):	
Operational conditions	approx. 1 kΩ
Overfill alarm	approx. 12 kΩ
Switching time	approx. 20 ms
Level switch (FR-contact):	
Operational conditions	approx. 47 Ω (contact protective resistor)
Overfill alarm	approx. ∞ (contact opened)
Switching time	approx. 20 ms
Permiss. filling material temperature ^(b) :	-20°C ... +150°C (T-205/0 resp. T-207/0: max. 100°C) (Version with PP-19: max. 90°C)
	-20°C ... +80°C (T-200.F with installed measuring transducer)
	-20°C ... +90°C (Plastic version T-200 / T-208)
Ambient temperature:	-20°C ... +60°C

^(a) For Ex Applications: observe permissible Ex-Data according to Ex-certificate

^(b) For Ex Applications: observe permissible temperature range according to Ex-certificate

1.4.5 Technical data for measuring transducer (2):

Type	ET-520.. / ET-521	ET-522
Mains supply:		
Rated operat. voltage	24 (20 ... 35) VDC	24 (20 ... 35) VDC
On request: (± 10 %)		
Rated frequency		
Power consumption		
On request:		
Power consumption	≤ 1 W	≤ 1 W
Output:		
Output relay	1 potential-free changeover-contact	Breaker or maker
Switching voltage	max. 250 VAC max. 150 VDC	max. 24 VDC
Switching current	max. cos φ = 1 ⇒ 3 A max. cos φ = 0.7 ⇒ 1 A	max. 200 mA DC
Switching power	max. 500 VA / W (30VDC) 10 W	≤ 5 W
Optocoupler	1 pot.fr. semi-cond. sw max. 30 VDC / 100 mA	
Input:		
Open circuit voltage	< 10 V	< 10 V
Short-circuit current	< 10 mA	< 5 mA
Switching delay	< 0.5 s	
Operating temperat.	-20 ... + 60°C	-20 ... + 60°C
Protecting type acc. to EN 60529	IP 65	IP 65

Type	KR-163/A.. resp. KR-163/B..	KR-163/A/Ex ..	KR-268.. resp. KR-168x..	XR-...	FR (ET-R...)
Mains supply:					
Rated operating voltage	230 VAC (+10% / -15%)	230 VAC (+10% / -15%)	230 VAC (+10% / -15%)	20 .. 230VAC/DC	24 V (±10%)
On request: (± 10 %)	24; 42; 48; 110; 115; 127; 240; VAC	24; 42; 48; 110; 115; 127; 240; VAC		24 V DC 230 V AC	
Rated frequency	48 ... 62 Hz	48 ... 62 Hz	48 ... 62 Hz	max. 62 Hz	
Power consumption	≤ 3 VA		≤ 3 VA	≤ 2 VA / W	≤ 0.4 W
On request:	24 (20...35) VDC	24 (20...35) VDC	24 (20...35) VDC		
Power consumption	≤ 2 W		≤ 2 W		
Output:					
Output relay	2 potential-free changeover-contacts	1 potential-free changeover-contact	per Output: 1 potential-free changeover-contact	2 potential-free changeover-contacts	
Switching voltage	max. 250 VAC max. 150 VDC	max. 250 VAC max. 150 VDC	max. 250 VAC max. 150 VDC	max. 250 V	max. 24 V
Switching current	max. cos φ = 1 ⇒ 3 A max. cos φ = 0.7 ⇒ 1 A	max. cos φ = 1 ⇒ 3 A max. cos φ = 0.7 ⇒ 1 A	max. cos φ = 1 ⇒ 3 A max. cos φ = 0.7 ⇒ 1 A	max. 5 A	max. 80 mA
Switching power	max. 1250 VA / W (30VDC/5A) 150 W	max. 100 / 50 VA / W (30 VDC) 10 W	max. 500 VA / W (30VDC) 10 W	max. 100 VA ; max. 50 W	max. 2 W
Input:		DIN EN 60947-5-6			
Open circuit voltage	8.6 ... 9.6 V	8.6 ... 9.6 V	8.6 ... 9.6 V	max. 14.8 VDC	
Short-circuit current	8.2 ... 10.2 mA	8.2 ... 10.2 mA	8.2 ... 10.2 mA	max. 5.6 mA	
Switching delay	< 0.5 s	< 0.5 s	< 0.5 s	adjustable 0.5 / 2 / 2.5 / 10	
Operating temperature	-20 ... + 60 °C	-20 ... + 60 °C	-20 ... + 60 °C	-20 ... + 60 °C	
Protective type according to EN 60529	IP 20	IP 20	IP 20	IP 20 Housing: IP 40	

Type	ET-580	OAA-100-A1...	OAA-100-A3..	OAA-200..	OAA-300..	OAA-500..
<u>Mains supply:</u>						
Rated operat. voltage	20 .. 230 V AC/DC	230 VAC (+10% / -15%)	230 VAC (+10% / -15%)	24 .. 230 V AC/DC	230 VAC (+10% / -15%)	42...253 VAC 20 ...60 VDC
On request: ($\pm 10\%$)		24; 115; 240 VAC	24; 115; 240 VAC		24; 115; 240; VAC	
Rated frequency		48 ... 62 Hz	48 ... 62 Hz		48 ... 62 Hz	48 ... 62 Hz
Power consumption		≤ 3 VA	≤ 1 VA / W	max. 2 VA / W	≤ 3 VA	≤ 3 VA / W
On request:		24 (20...35) VDC	24 (20...35) VDC		24 (20...35) VDC	
Power consumption	≤ 1 W	≤ 2 W	≤ 2 W		≤ 3 W	
<u>Output:</u>						
Output relay	2 potential-free changeover- contacts	2 potential-free changeover-contacts; 2 makers	2 potential-free changeover-contacts	2 potential-free changeover-contacts	6 potential-free changeover-contacts	2 potential-free changeover- contacts
Switching voltage	max. 250 V AC/DC	max. 250 VAC max. 150 VDC	max. 250 VAC max. 150 VDC	max. 250 V AC/DC	max. 250 VAC max. 150 VDC	max. 250 VAC max. 115 VDC
Switching current	max. 5 A	max. 3 A	max. 3 A	max. 5 A	max. 3 A	max. 3 A
Switching power	max. 500 VA / W (30VDC) 10 W	max. 500 VA / W (30VDC/5A) 150 W	max. 500 VA / W (30VDC/5A) 150 W	max. 1250 VA max. 50 W	max. 500 VA / W (30VDC/5A) 150 W	max. 500 VA / W (30VDC) 10 W
Optocoupler						
<u>Input:</u>						
Open circuit voltage	< 10 V	< 10 VDC	< 10 V	max. 3.3 VAC	< 10 VDC	< 24 VDC
Short-circuit current	< 5 mA	< 10 mA	< 10 mA	max. 1 mA	< 10 mA	< 20 mA
Switching delay		< 0.5 s	< 0.5 s		< 0.5 s	< 0.5 s
Operating temperat.	-20 ... + 60°C	-20 ... + 60°C	-20 ... + 60°C	-20 ... + 60°C	-20 ... + 60°C	-20 ... + 60°C
Protecting type acc. to EN 60529	IP 00	Housing: IP 65	IP 20	Housing: IP 65	Housing: IP 65	Version A1: IP 65 Version A2: IP 20

2. Materials of the level switch

The parts of the level switch which come into contact with the liquid, its vapours or condensate, are manufactured of stainless austenitic steel.

In special cases, titanium or Hastelloy can also be used.

Media-resistant plastic materials are used for the plastic versions T-200.F resp. T-208.F.

3. Application areas of the level switch

The level switches (including those with integrated switching amplifier) are suitable for use in containers with pressures up to 20 bar.

The following ranges regarding the filling material temperatures are possible:

- Metal immersible probes T-20...: -20°C ... +150°C
(T-205/0 resp. T-207/0: -20°C ... +100°C / to +90°C with version with PP-19)
- Plastic versions T-20...: -20°C ... +90°C
- Version with integrated switching amplifier T-20.F D(24V) -20°C ... +80°C
- Version with integrated switching amplifier T-20.FR -20°C ... +80°C

The level switches are suitable for use in storage liquids whose viscosity does not exceed 150 mm²/s (e.g. olive oil approx. 120 mm²/s) and whose solid material diameter is < 200 µm (information about media density can be found in 1.4.2).

4. Malfunction messages, Error messages

4.1 Malfunction messages, Error messages

Disconnection or short-circuit of the signal line between the level switch (1), T-20_F... and the measuring transducer (2), as well as power failure effect – due to the quiescent current principle employed - a drop of the output changeover contacts of the measuring transducer (2) to "Alarm position".

If the response level is reached, it is indicated on the measuring transducer (2) by the red LED and the power indicator (green LED) extinguishes in the case of line disconnection resp. short-circuit.

At T20_FR, an interruption of the signal line causes an interruption of the connection line or the reaching of the response level. The evaluation is carried out in the downstream signaling device (eg. PLC).

5. Installation and connection information

5.1 Installation of the level switch

The level switches are suitable for vertical installation from the top (except T-206). It may be necessary to dismantle the floaters when installing the level switch.

In this case you must proceed as follows:

(Explanation for level switch with one floater)

1. Remove tapered dowel pin (only for EX-version)
2. Take out cap nut, spring ring, washer, and buffer washer (⇒ Ex-metal version) **or** only unscrew the bottom stop (⇒ Metal resp. plastic version)
3. Remove floater from pipe
4. Insert level switch in screw opening
5. Slide floater back over the guide pipe (curvature to top! Pay attention to "TOP")
6. Re-attach buffer washer, washer, spring ring and cap nut in the sequence as before on the guide tube or only screw stop back on (see 2.)
7. Assemble tapered dowel pin in original position (only with EX-version)
8. Screw in screw connection with sealing tape

When removing the stop rings in the case of level switches with several floaters, mark their positions on the guide tube.

When sliding back onto the tube, the stop rings must be arrested in their original positions by tightening the locking screws.

Attention: In the case of the EX-version attention must be paid that the buffer washers are re-positioned correctly (to avoid sparking)!

5.2 Connection of the level switch with switching amplifier

When connecting the switching amplifier **KR-...** resp. **XR-...** please proceed according to the connection diagram. The signal line must be connected to terminals 1 and 2 (terminal 1 to E0 resp. terminal 2 to E1), which are marked additionally with an "F", in general on the level switch. The measuring transducers must be installed with observance of the max. permissible line resistance ($\leq 50 \Omega$) of the signal line. Provide over-current protection, such as a fuse (250mA) or circuit breaker, to limit fault currents on supply wiring.

The alarm devices and / or control devices must be connected to the potential-free output contacts as required.

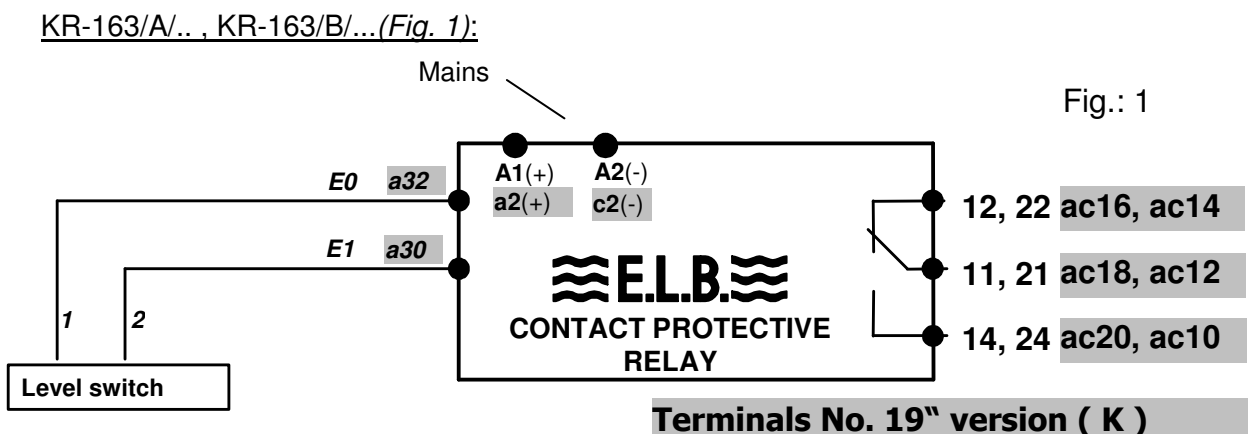

E.L.B. Füllstandsgeräte

Overfull cut-out device with level switch for stationary containers to store liquids hazardous to water

z-65.11-404_englischeBeschr_Juli2019.doc

Status: 03.07.2019

Page: 23/30

KR-163/A/Ex.. (Fig. 2):

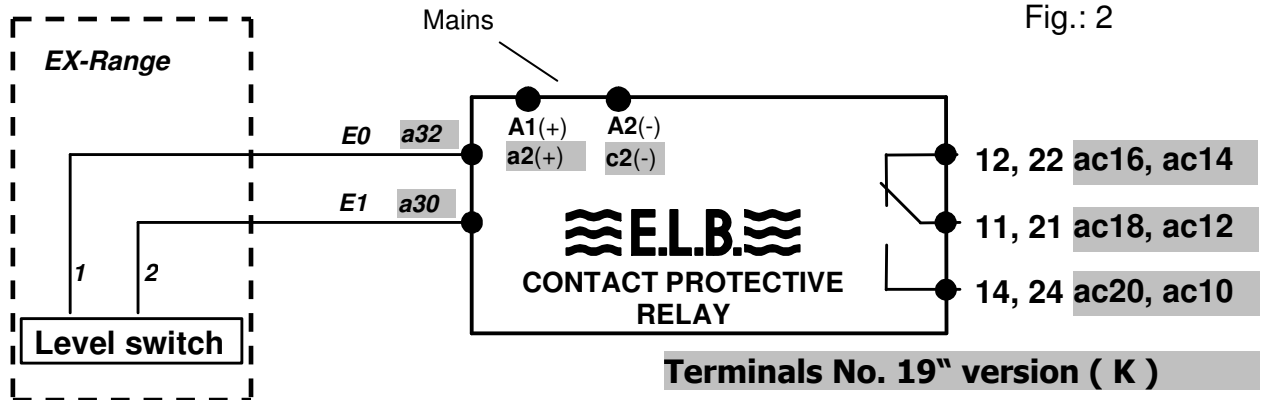

ET- 520.. (Fig. 3a), ET-521 (Fig. 3b), ET-522 (Fig. 3c):

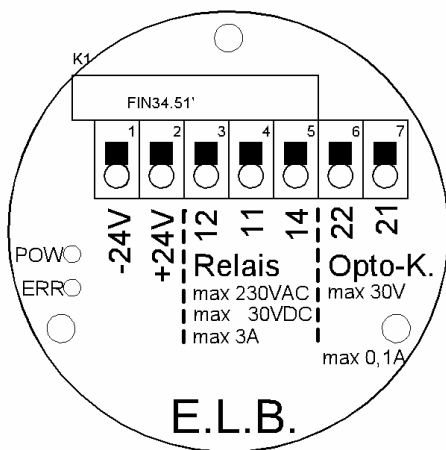
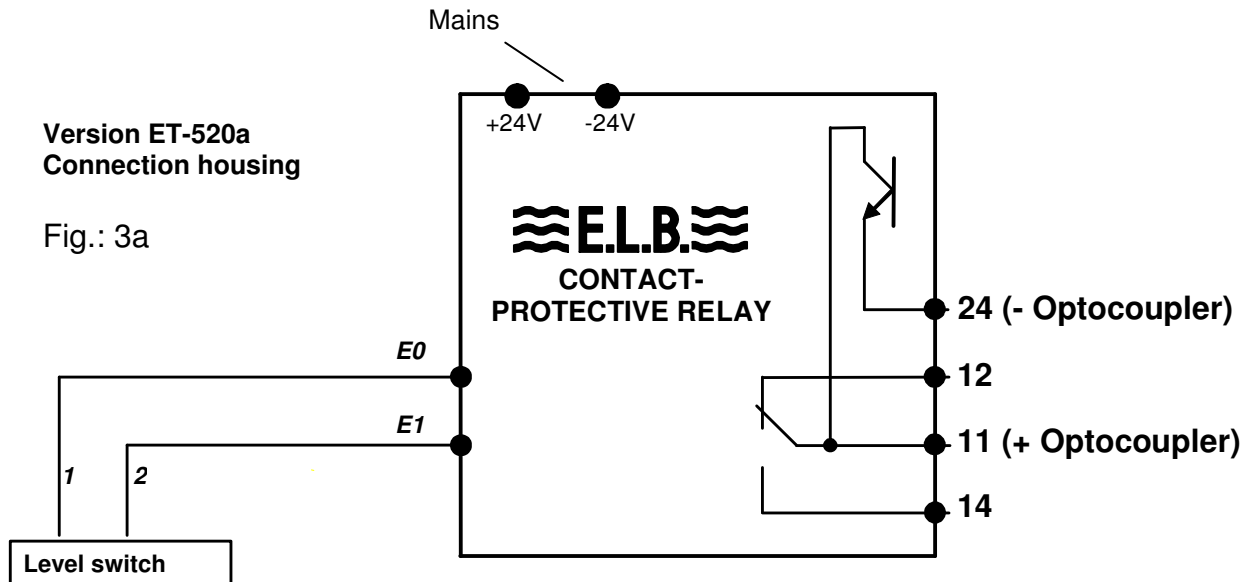

Version ET- 521
Connection housing

Fig.: 3b

ELB Füllstandsgeräte

Overfull cut-out device with level switch for stationary containers to store liquids hazardous to water

z-65.11-404_englischeBeschr_Juli2019.doc

Status: 03.07.2019

Page: 24/30

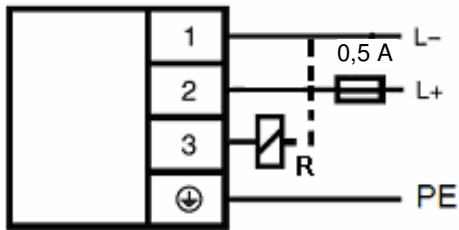

Version ET- 522
1-Channel Version

Fig.: 3c

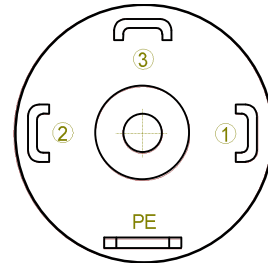

ET - 580 (Fig. 4):

The mains connection (20 ... 230 V) of the transducer ET-580 is to be put on clamp 1 („+“) and clamp 2 („-“).

change over switch 1: clamp 3 = NC
clamp 4 = COM
clamp 5 = NO

change over switch 2: clamp 6 = NC
clamp 7 = COM
clamp 8 = NO

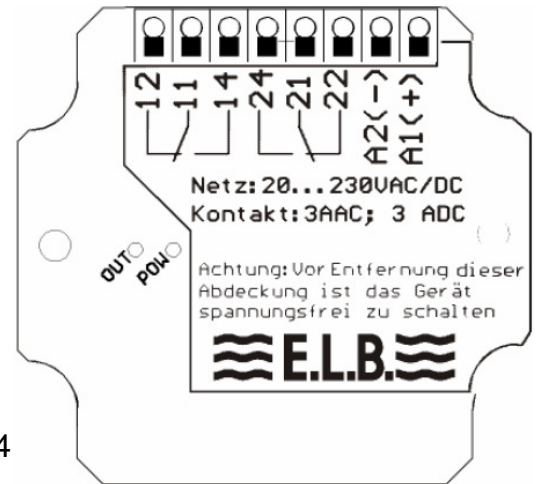

Fig.: 4

KR-168 / B 1-Channel Version (Fig. 5):

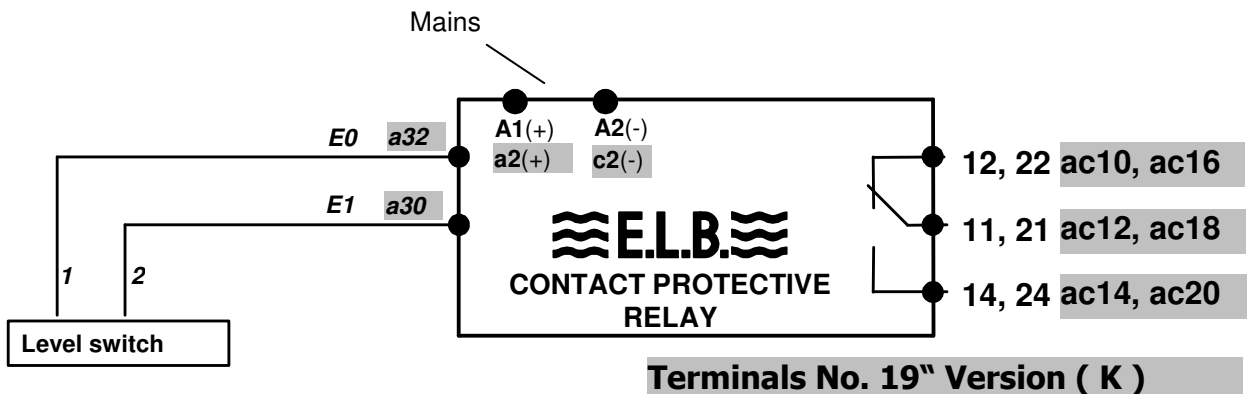

Fig.: 5

ELB Füllstandsgeräte

Overfull cut-out device with level switch for stationary containers to store liquids hazardous to water

z-65.11-404_englischeBeschr_Juli2019.doc

Status: 03.07.2019

Page: 25/30

KR-268 / B 2-Channel Version (Fig. 6):

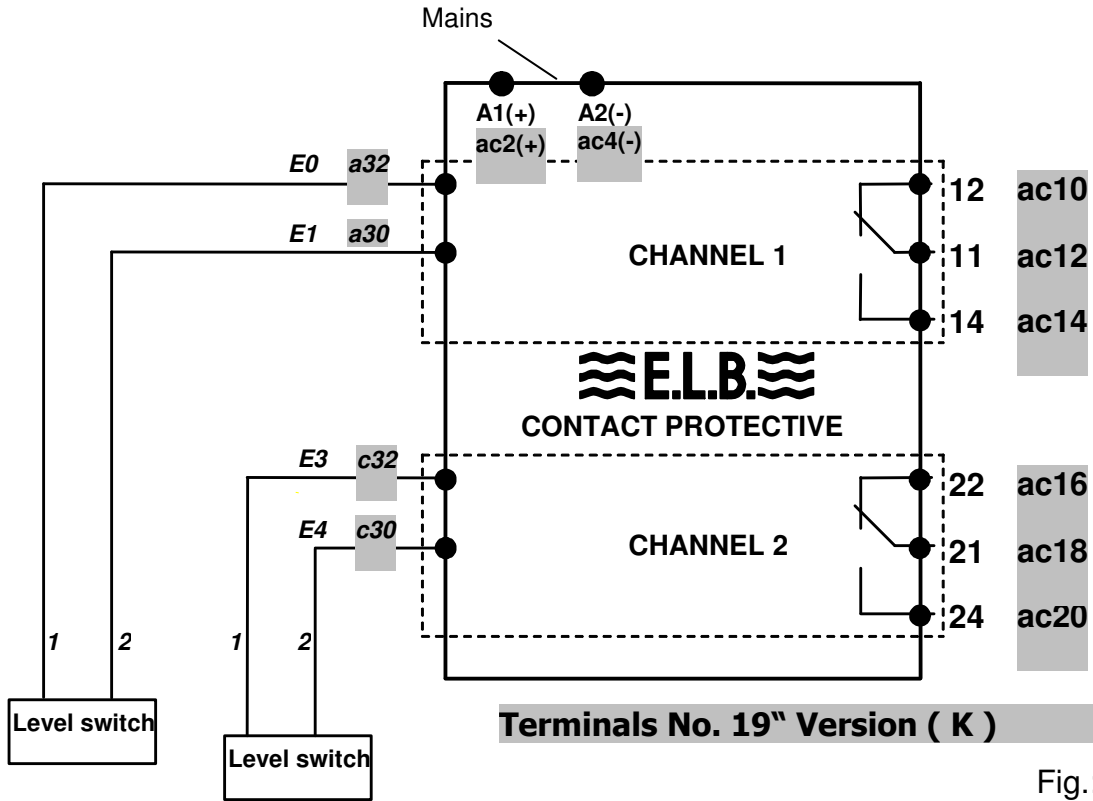

Fig.: 6

XR-.. (Fig. 7):

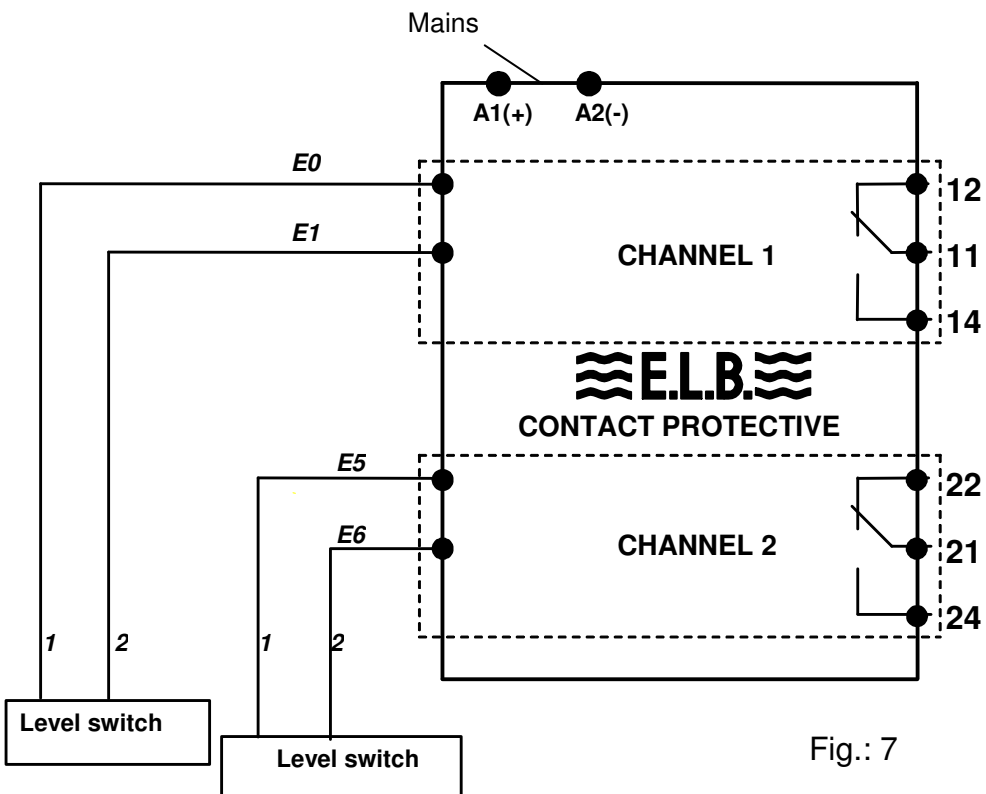

Fig.: 7

ELB Füllstandsgeräte

Overfull cut-out device with level switch for stationary containers to store liquids hazardous to water

z-65.11-404_englischeBeschr_Juli2019.doc

Status: 03.07.2019

Page: 26/30

FR [ET-R...] (Fig. 8):

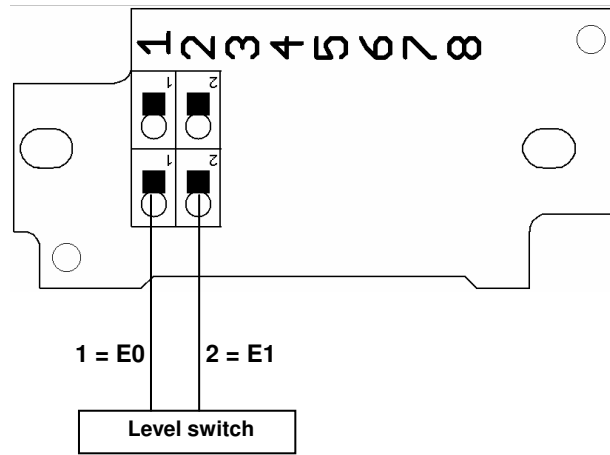

Fig.: 8

OAA 100-A1 (Fig.9)

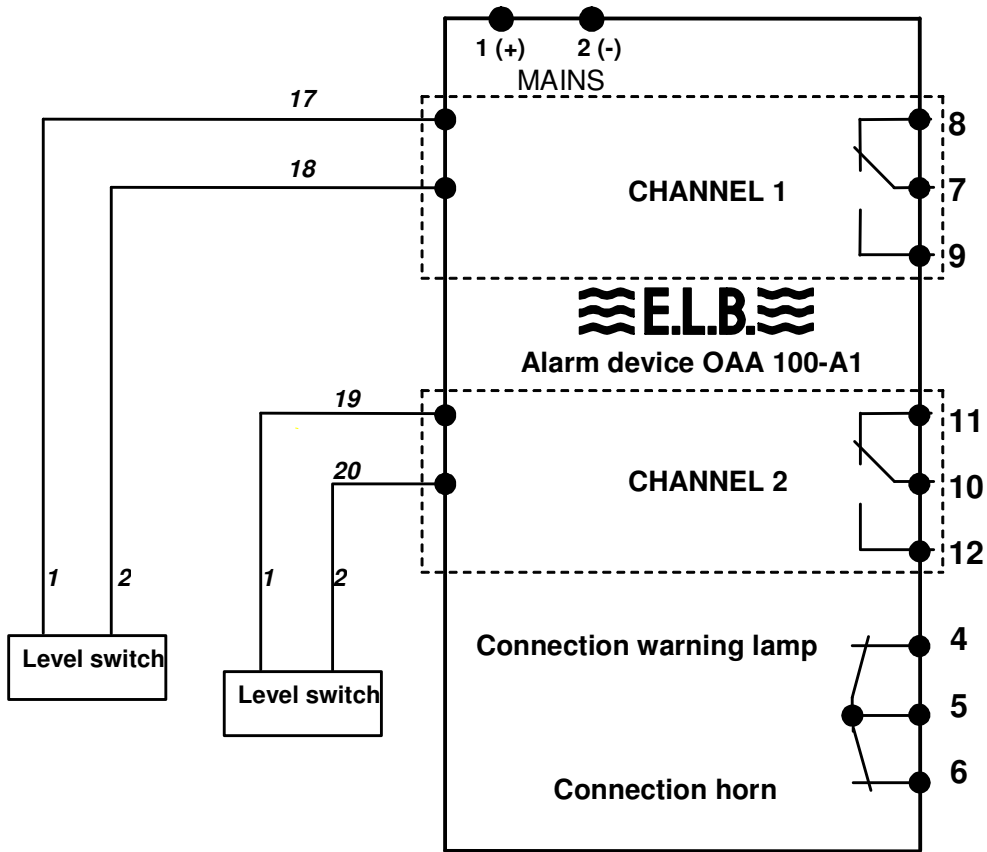

Fig.: 9

ELB Füllstandsgeräte

Overfull cut-out device with level switch for stationary containers to store liquids hazardous to water
 z-65.11-404_englischeBeschr_Juli2019.doc Status: 03.07.2019 Page: 27/30

OAA 100-A3 (Fig.10)

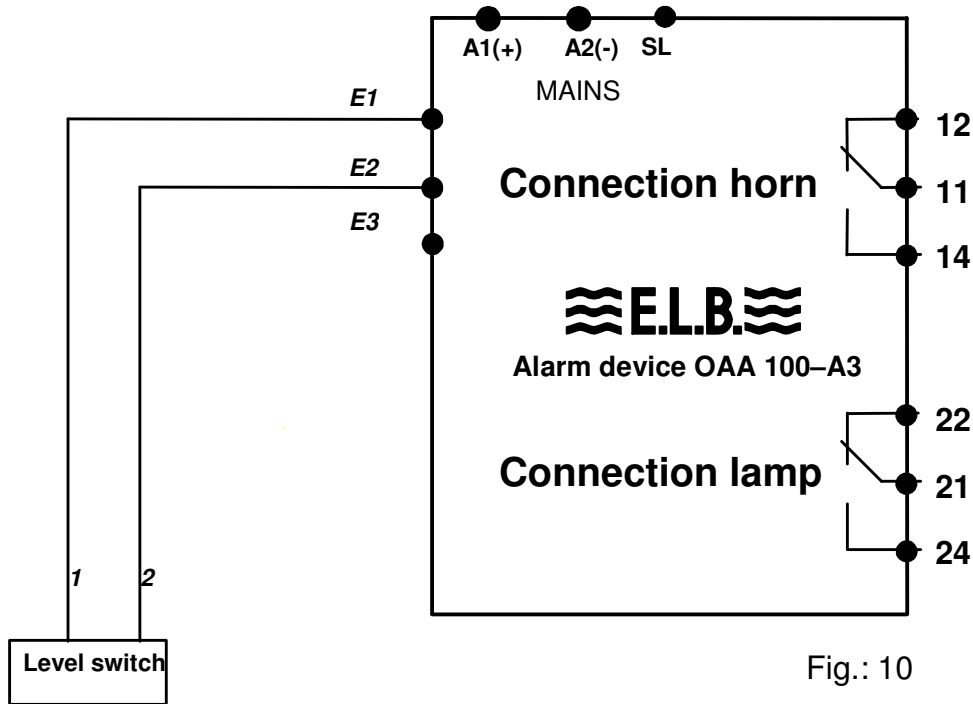

Fig.: 10

OAA-200... Optical and Acoustic Warning Device (Fig.11)

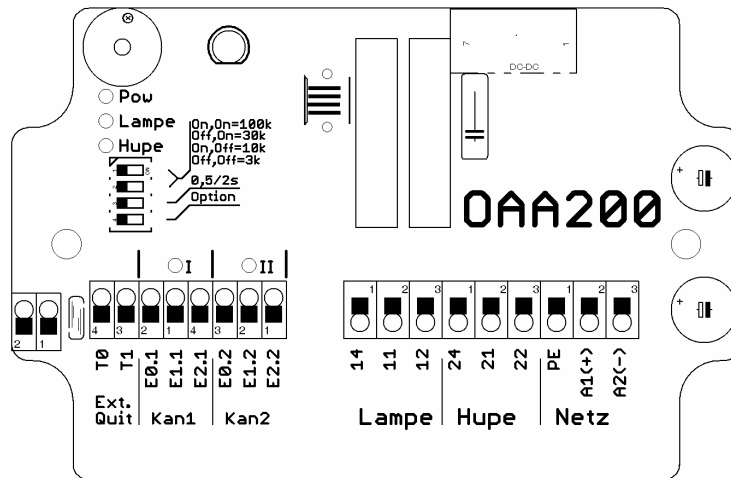

Fig.: 11

Terminal assignment OAA-200

The mains connection	PE	A2 = L (+)	A1 = N (-)
Output relay lamp	11 = COM	12 = NC	14 = NO
Output relay horn	21 = COM	22 = NC	24 = NO
Channel 1		E 0.1	E 1.1
Channel 2		E 0.2	E 1.2
Input ext. acknowledgem.	TO, T1 pot.-free contact		

If the alarm is on, the horn can be turned off by pressing the side button. Further alarm messages turn the horn again. The collective interference lamp cannot be turned off with the side button until there are no more alarm messages left. The alarm can be acknowledged externally also by means of a potential-free contact.

OAA-300... Optical and Acoustic Warning Device (Fig. 12)

Mains

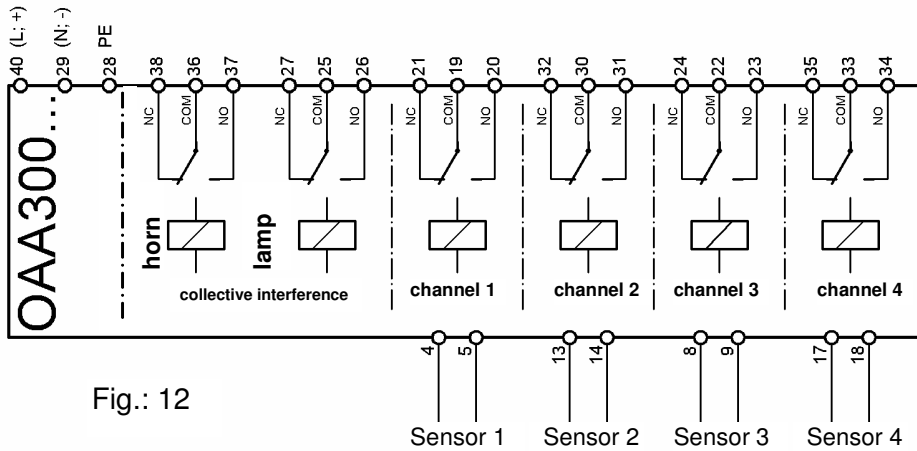

Fig.: 12

Terminal assignment OAA-300				
The mains connection	28, 39 = PE	29 = N (-)	40 = L (+)	
Output relay Channel 1	19 = COM	20 = NO	21 = NC	
Output relay Channel 2	30 = COM	31 = NO	32 = NC	
Output relay Channel 3	22 = COM	23 = NO	24 = NC	
Output relay Channel 4	33 = COM	34 = NO	35 = NC	
Output relay horn	36 = COM	37 = NO	38 = NC	
Output relay lamp	25 = COM	26 = NO	27 = NC	
Sensor 1		4 = E0	5 = E1	
Sensor 2		13 = E0	14 = E1	
Sensor 3		8 = E0	9 = E1	
Sensor 4		17 = E0	18 = E1	
Input ext. acknowledgem.	1, 10 pot.-free contact			

If the alarm is on, the horn can be turned off by pressing the *Quit* button. Further alarm messages turn the horn again. The collective interference lamp cannot be turned off with the *Quit* button until there are no more alarm messages left. The alarm can be acknowledged externally also by means of a potential-free contact.

OAA-500-... Optical and Acoustic Warning Device (Fig. 13, 14):

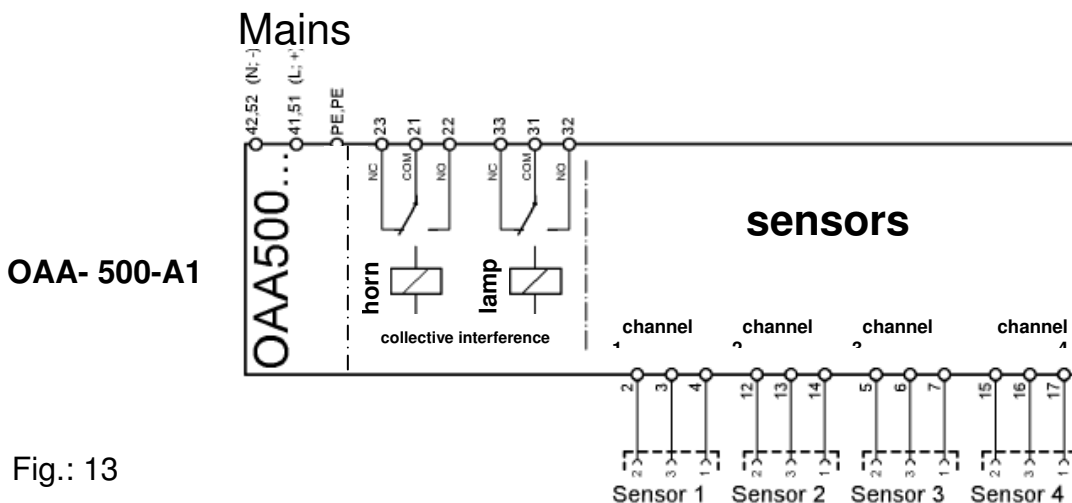

Fig.: 13

ELB Füllstandsgeräte

Overfull cut-out device with level switch for stationary containers to store liquids hazardous to water

z-65.11-404_englischeBeschr_Juli2019.doc

Status: 03.07.2019

Page: 29/30

Terminal assignment OAA-500-A1			
The mains connection	PE	41, 51 = L (+)	42, 52 = N (-)
Output relay lamp	31 = COM	32 = NO	33 = NC
Output relay horn	21 = COM	22 = NO	23 = NC
Sensor 1	2 = + 12 VDC	3 = Input (12 VDC)	4 = GND (-)
Sensor 2	12 = + 12 VDC	13 = Input (12 VDC)	14 = GND (-)
Sensor 3	5 = + 12 VDC	6 = Input (12 VDC)	7 = GND (-)
Sensor 4	15 = + 12 VDC	16 = Input (12 VDC)	17 = GND (-)
Input ext. acknowledgem.	1, 11 pot.-free NO-contact		

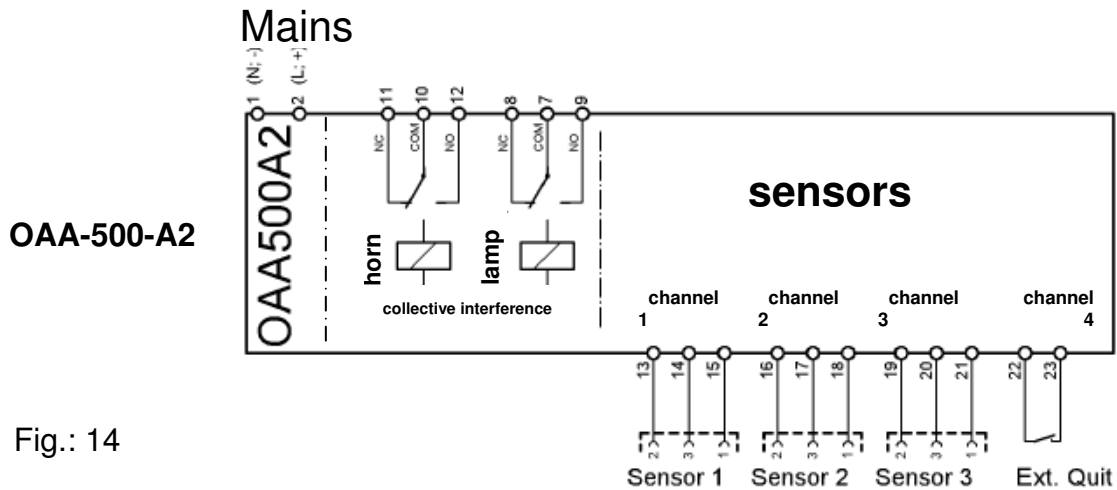

Fig.: 14

Terminal assignment OAA-500-A2			
The mains connection		2 = L (+)	1 = N (-)
Output relay lamp	7 = COM	9 = NO	8 = NC
Output relay horn	10 = COM	12 = NO	11 = NC
Sensor 1	13 = + 12 VDC	14 = Input (12 VDC)	15 = GND (-)
Sensor 2	16 = + 12 VDC	17 = Input (12 VDC)	18 = GND (-)
Sensor 3	19 = + 12 VDC	20 = Input (12 VDC)	21 = GND (-)
Input ext. acknowledgem.	22, 23 pot.-free NO-contact		

6. Setting information

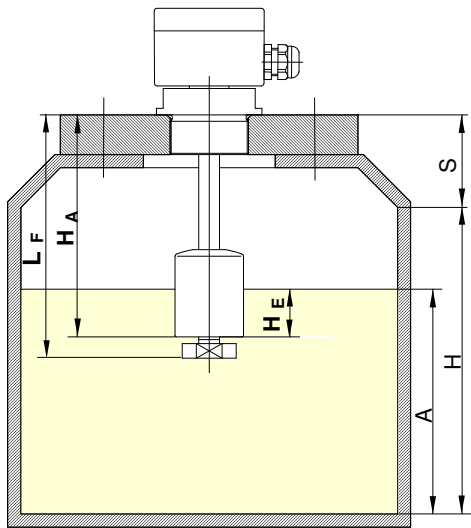

Diagram to determine the response length H_A

Corresponding with the permissible container filling degree, and with the help of the approval principles for overfull cut-out devices, (German ZG-ÜS) the liquid level, which corresponds with the response level of the overfull cut-out device, must be determined. The tailing quantity as well as the switching resp. closing delay times must be taken into consideration here.

The response length of the level switch can be determined as follows from these:

$$H_A = (H - A) + S + H_E$$

- H_A = Response length
- H = Container height
- A = Response height
- S = Nozzle, resp., flange height above the container
- H_E = Immersion depth of the floater

(s)

ee diagram page 15)

fixed version

$$L_F = (H + S) - A + H_E + 20 \text{ mm}$$

adjustable version

$$L_F \geq (H + S) - A + H_E + 70 \text{ mm}$$

The response length H_A is fixed in the plant according to customer requirements and must be determined before placing the order. Level switches with adjustable screw-in part allow subsequent re-adjustment to a certain degree on site.

7. Operating instructions

When used as intended, the overfull cut-out device, consisting of the level switch T-20_.F... and the measuring transducer (2) KR-16..., KR-26..., XR..., OAA 100..., OAA 200..., OAA 300...; OAA 500... or the level switch T-20_.FR... with integrated measuring transducer (2) or the level switch T-20_.FR...(1,2) (ET-5... or float – magnetic switch) works maintenance-free. The system parts of the overfull cut-out device must have indicating, resp. control devices connected downstream. The output contacts are used for this purpose.

Before the set-to-work, all equipment parts of the overfull cut-out device must be checked for correct connection and function.

The general Operating Instructions of the used equipment must be observed.

8. Recurrent inspection

The good working order of the overfull cut-out device must be checked in appropriate periods but at least once a year. It is the responsibility of the operator to select the type of inspection and the intervals in the stated time frame.

The inspection test must be conducted so that the faultless functioning of the overfull cut-out device in cooperation with all components is proven. This is guaranteed during approach of the response height within the scope of a filling process. If a filling up to the response height is not practical, the level switch must be brought to respond with a suitable simulation of the filling level or the physical measuring effect. If the good working order of the level switch/measuring transducers can be identified in another manner (exclusion of function-inhibiting errors), the inspection test can also be conducted by simulating the corresponding output signal. Further information about the inspection test methods can be found, e.g. the guideline VDI/VDE 2180, sheet 4.